



**FUJI**  
**ELECTRIC**

**ROOM AIR CONDITIONER**

**RK-7AQ**

**RK-9AP**

# **SERVICE MANUAL**

## **C O N T E N T S**

SPECIFICATIONS .....	1
CIRCUIT DIAGRAM .....	2
DISASSEMBLY ILLUSTRATION .....	3
PARTS LIST .....	7



**Большая библиотека технической документации**

<https://splitsystema48.ru/instrukcii-po-ekspluatatsii-kondicionerov.html>

**каталоги, инструкции, сервисные мануалы, схемы.**

# SPECIFICATIONS

MODEL		RK-7AQ	RK-9AP
COOLING CAPACITY	(kW)	2.10	2.50

## ELECTRICAL DATA

POWER SOURCE		(V)	220	
FREQUENCY		(Hz)	50	
COOLING	RUNNING CURRENT	(A)	3.6	4.2
	INPUT WATTS	(kW)	0.78	0.90
	EER	(kW/kW)	2.69	2.78

## COMPRESSOR

TYPE		Hermetic type, Rotary type	
CODE		QK134PAE 3 Leg 220-240V 50Hz	QK164PAC 220-240V 50Hz
REFRIGERANT	R-22 (g)	500	750

## FAN MOTOR

CODE	MFC-09BTM 220-240V 50Hz		
HIGH POWER	(r.p.m.)	1,040	
SUPER QUIET	(r.p.m.)	800	

# CIRCUIT DIAGRAM

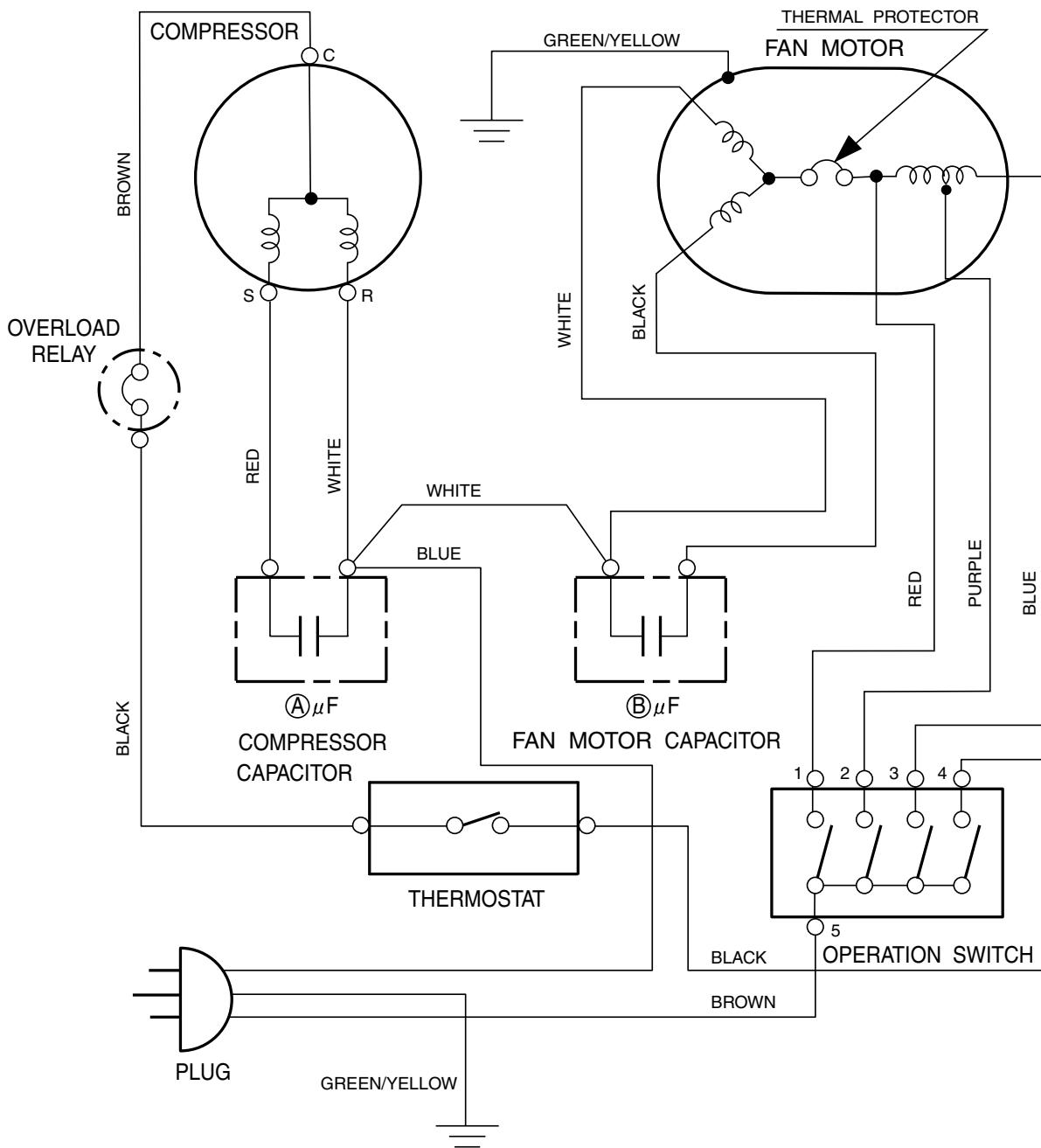

## OPERATION SWITCH INTERNAL CONNECTIONS

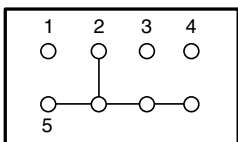

FAN

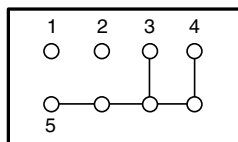

LOW

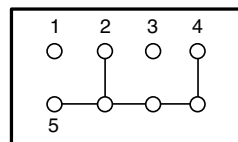

MED

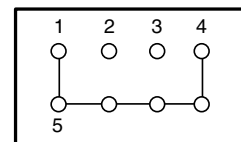

HIGH

	(A)	(B)
RK-7AQ	25	2.3
RK-9AP	30	2.3

# DISASSEMBLY ILLUSTRATION

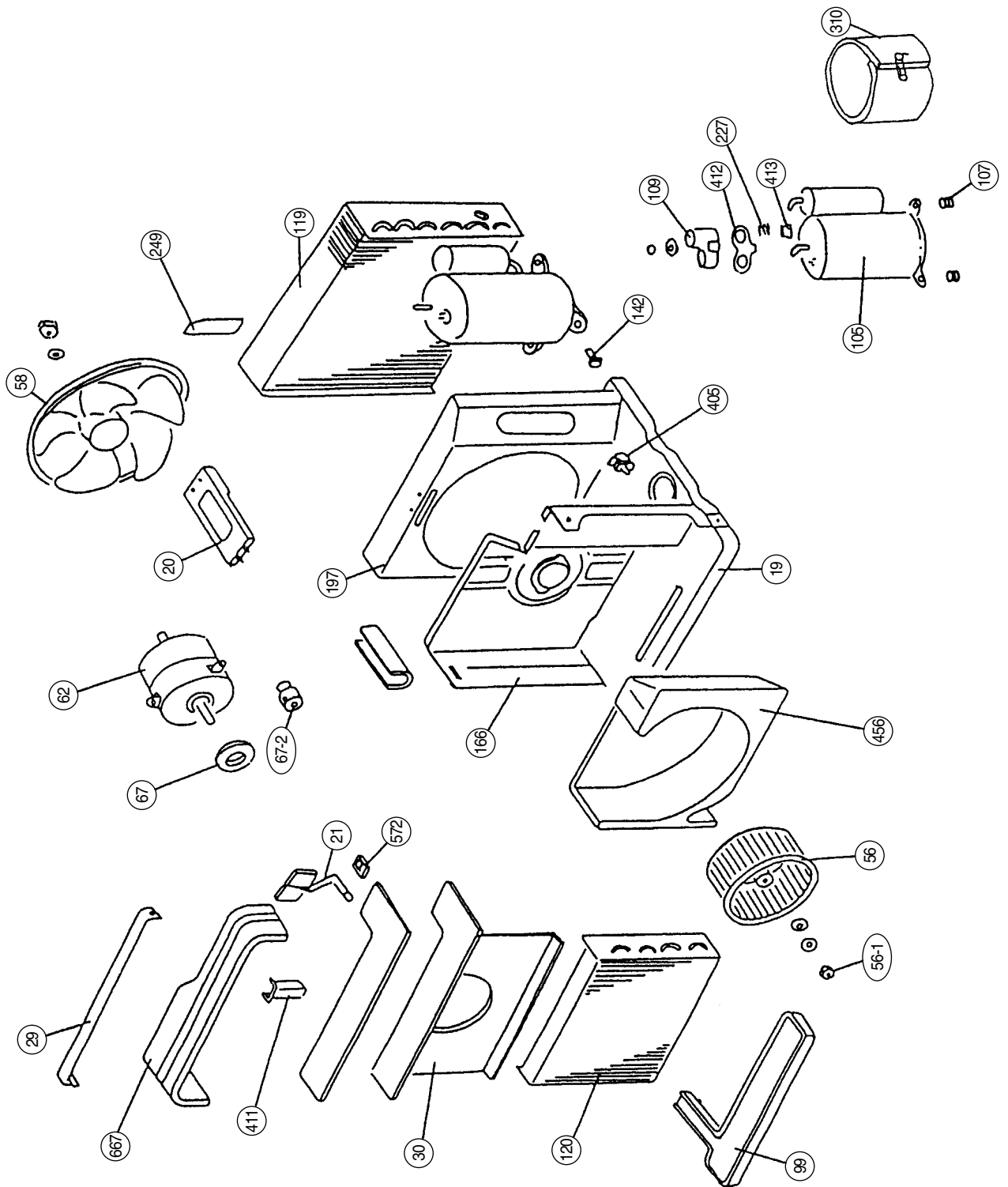

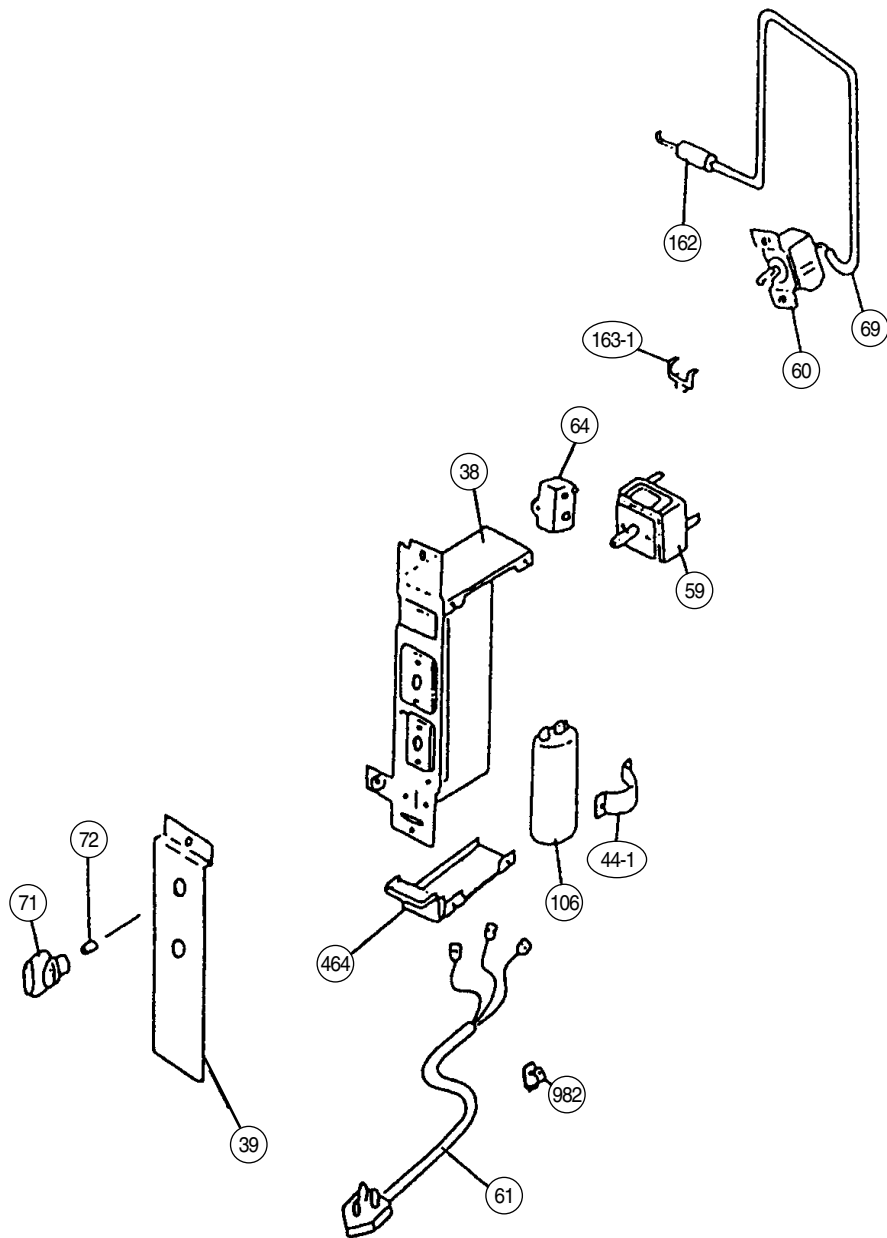

Model : RK-7AQ

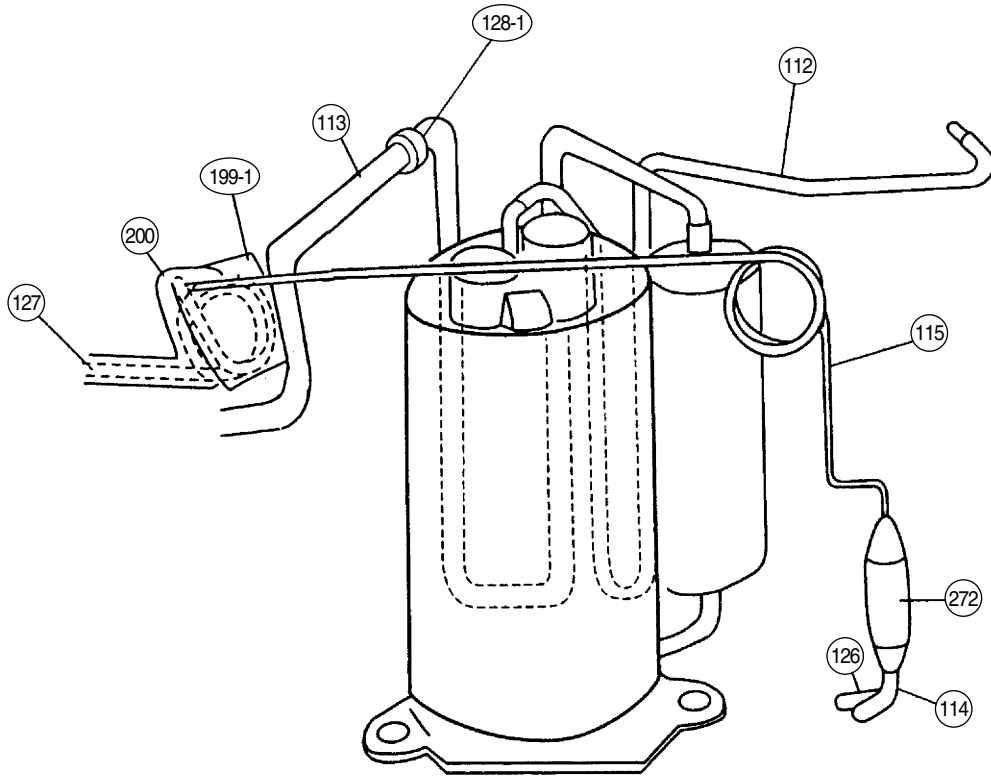

Model : RK-9AP

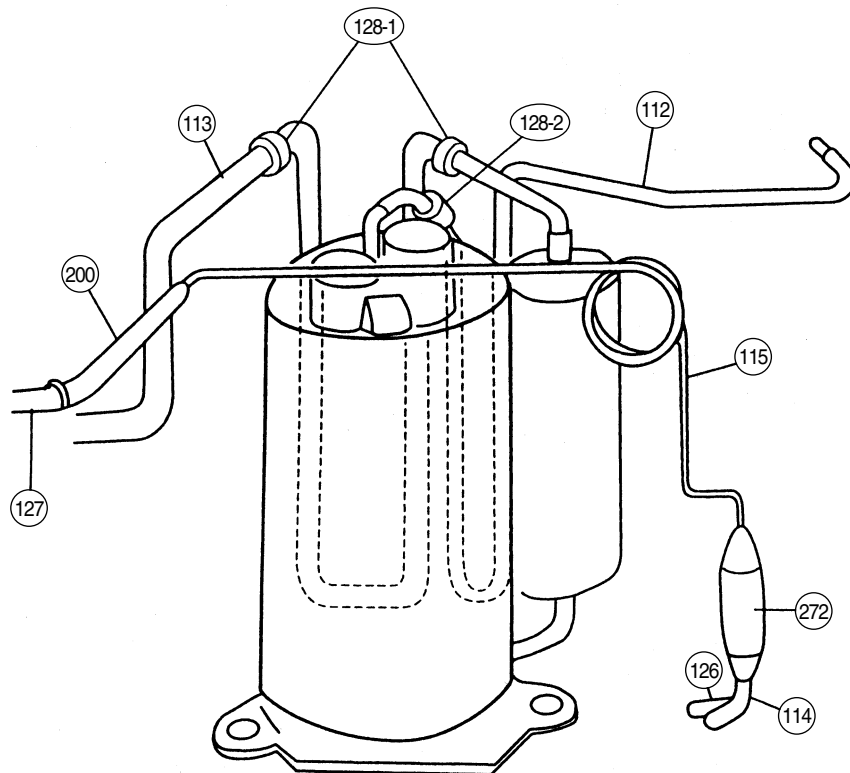

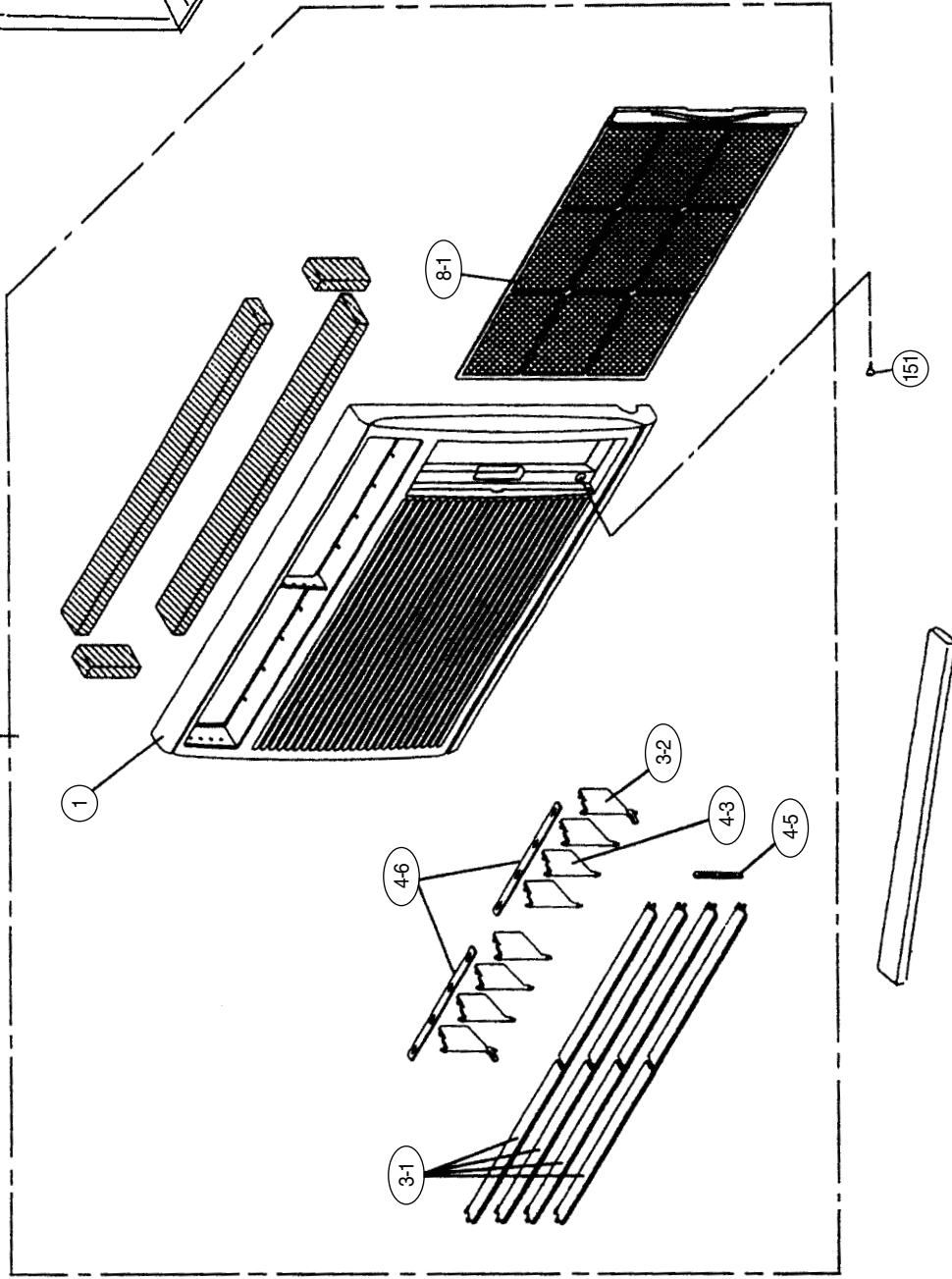
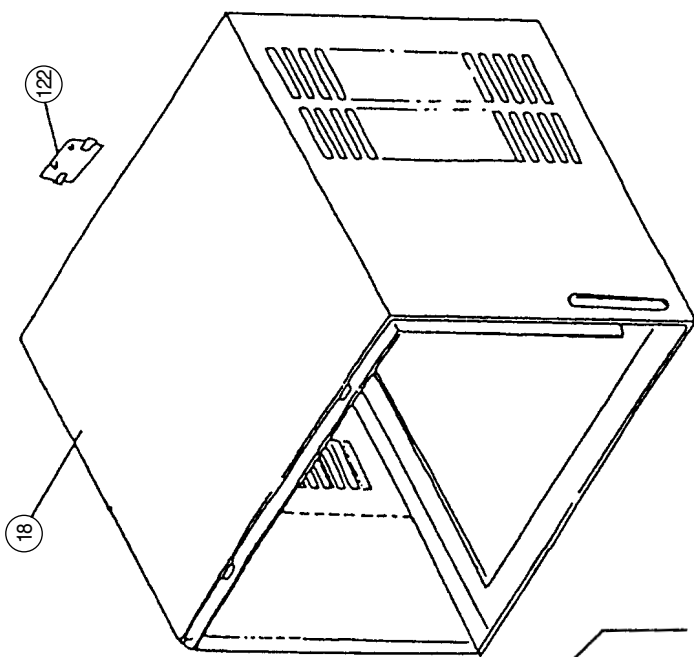

## PARTS LIST

## FRONT PANEL PARTS

When you order parts, please make a photocopy of this page and fill the number of the parts in the "Order" column.

Ref. No.	Description	Part No.	Ord. Q'ty	Ref. No.	Description	Part No.	Ord. Q'ty
1	Front Panel	9361838017		4-5	Connecting Plate-A	9358102015	
3-1	Louver-A	9361840010		4-6	Connecting Plate-B	9358103012	
3-2	Louver-C	9358101018		8-1	Filter	9361842021	
4-3	Louver-B	9358100011		15-B	Front Panel Assy	9362575027	

## CABINET CHASSIS PARTS

Ref. No.	Description	Part No.		Ord. Q'ty	Ref. No.	Description	Part No.		Ord. Q'ty
		RK-7AQ	RK-9AP				RK-7AQ	RK-9AP	
18	Cabinet Assy	9389020067	9389020067		114	Air Duct Pipe-E	313252257206	313252257206	
19	Base Assy	9389017081	9389017081		115	Capillary Tube	9362061001	9363298000	
20	Supporter-C	9358091005	9358091005		119	Condenser Assy	9358132029	9367029013	
21	Exhaust Air Damper	9358094020	9358094020		120	Evaporator Assy	9358131015	9358131015	
29	Supporter-B	9358089002	9358089002		122	Emblem-B (Rear)	9358104040	9358104040	
30	Blower Mouth	9358084007	9358084007		126	Condensing Pipe-B	9358923009	9363368000	
38	Switch Box-A Assy	313107242805	313107242805		127	Inlet Pipe (Evaporator)-B	9366005001	9359748014	
39	Switch Panel	9358134092	9358134092		128-1	Rubber (Discharge Pipe)	313155086308	313155086308	
44-1	Capacitor Band (Running Capacitor)	313106061706	313306061707		128-2	Rubber (Discharge Pipe)	—	313202086308	
					142	Drain Pipe	9351674007	9351674007	
56	Sirocco Fan	9358107010	9358107010		151	Front Panel Screw	313306389909	313306389909	
56-1	Nut For Sirocco Fan	9358135006	9358135006		162	Thermostat Holder	313616262803	313616262803	
58	Propeller Fan	9358106013	9358106013		163-1	Thermostat Spring-A	313668262714	313668262714	
59	Operation Switch	9370012026	9370012026		166	Separate Wall Assy	9358114018	9358114018	
60	Thermostat	9370013016	9370013016		197	Wind Guide Board	9358092026	9358092026	
61	Power Cord Assy	9703286025	9703286025		199-1	BR Sheet	313612108209	—	
62	Fan Motor Assy	9601050001	9358334003		200	BR Sheet-B	9359189008	9359189008	
64	Capacitor (Fan Motor)	9703124013	9703124013		227	Terminal Spring	9359429012	—	
67	Rubber (Vibration-proof)	313106068602	313106068602		249	Dew Proof Plate	313106041504	313106041504	
67-2	Rubber-B (Vibration-proof)	9358306000	9358306000		272	Strainer	9350663026	9350663026	
69	Protection Tube	313310060308	313310060308		310	Compressor Cover	9364291000	9364291000	
71	Thermostat Knob	9358105016	9358105016		405	Clamp No. 1763	313816345304	313816345304	
72	Knob Spring (Thermostat Knob)	313008061010	313008061010		411	Supporter-A	9358115015	9358115015	
99	Drain Pan	9358086001	9358086001		412	Terminal Gasket (For Comp.)	9362004008	9362004008	
105	Compressor Assy	9367018000	9367027002		413	Overload Relay	9362018005	9359927013	
106	Running Capacitor	9350973019	9350973026		456	Casing	9358082003	9358082003	
107	Rubber Seat-A (For Comp.)	9359425014	9359425014		464	Switch Box Cover-C	9358009024	9358009024	
109	Terminal Cover (For Comp.)	9359426011	9363263008		572	Holder (Ex. Air Damp.)	9358095010	9358095010	
112	Discharge Pipe	9362062008	9363296006		622	Bracket (Typhoon Lock)	9355799003	9355799003	
113	Suction Pipe Assy	9362060004	9363297003		667	Casing-Upper	9358088005	9358088005	
					982	Cord Clamp	9363471007	9363471007	





MANUFACTURER :

**Fuji Denki Sosetsu Co., Ltd.**

Tokyo, Japan



**Большая библиотека технической документации**

<https://splitsystema48.ru/instrukcii-po-ekspluatácii-kondicionerov.html>

**каталоги, инструкции, сервисные мануалы, схемы.**